



D I G I T A L T E C H N O L O G I E S F O R A B E T T E R W O R L D



SN

SENSORS NETWORK SOLUTIONS

2008/V1

Eurotech Group

Eurotech is a leading international technology group with headquarters in Italy and facilities throughout Europe, America and Asia. The Group's main focus is on the development of cutting-edge technologies that make our life better, safer, and more comfortable.

The fundamental assumption behind Eurotech's business strategy is the concept that as important technologies spread, they become increasingly integrated into our life, becoming nearly invisible.

Eurotech's role today is to support its customers in Sensors Network markets and to identify new customers in the emerging markets breaking traditional boundaries via innovation.

With this vision in mind, Eurotech has oriented its R&D activities to the key high-growth sectors, like pervasive computation. Their goal is to develop innovative, integrated solutions (software, hardware, middleware and support services) that offer the flexibility and scalability needed to capture new market opportunities and integrate them in the traditional markets.



Eurotech's strategy, which couples standard solutions with a flexibility that allows customization and innovation, has made them one of the world leaders in high technology for computer miniaturization.



www.eurotech.com



- ▶ **ZigBee Modules**
- ▶ **Wireless Devices**
- ▶ **Wearable Computers**

SN

**SENSORS NETWORK
SOLUTIONS**



TMS

**TRANSPORTATION,
MOBILITY
& SURVEILLANCE**

- ▶ **Wearable Computers**
- ▶ **Mobile Computers**
- ▶ **Embedded Boards**



DSA

**COTS PRODUCTS FOR
SECURITY, DEFENCE AND
AEROSPACE**

- ▶ **Stationary Computers**
- ▶ **Mobile Computers**
- ▶ **Wearable Computers**
- ▶ **Embedded Boards**



ICN

**INDUSTRIAL,
COMMERCIAL
& NETWORKING**

- ▶ **Wearable Computers**
- ▶ **Network Appliances**
- ▶ **Stationary Computers**
- ▶ **Panel Computers**
- ▶ **LCD Industrial Monitors**
- ▶ **Embedded Boards**

Table of Contents



SOLUTIONS

- ▶ **Industrial Scenario** 7
- ▶ **Temperature and humidity monitoring for Hospital/Biological Laboratory** 8



PRODUCTS

- ▶ **ZigBee modules** 9
- ▶ **Wireless Sensor Network** 12
- ▶ **Wearable Computers** 16



KEY FEATURES

- ▶ ZigBee Modules
- ▶ Wireless Devices
- ▶ Wearable Computers

A standard ZigBee™ or 802.15.4 is an excellent choice for many low power, low data rate wireless communication applications. However, is it really for everything? There are situations where 802.11 WLAN works very well for high data rate traffic. Similarly, there are applications that require long range and more battery life. ZigBee protocols are relatively light with respect to demands on code space (32-70 KB) and have a moderate range (10-100m). These make ZigBee a good choice for Industrial and Home Networking.

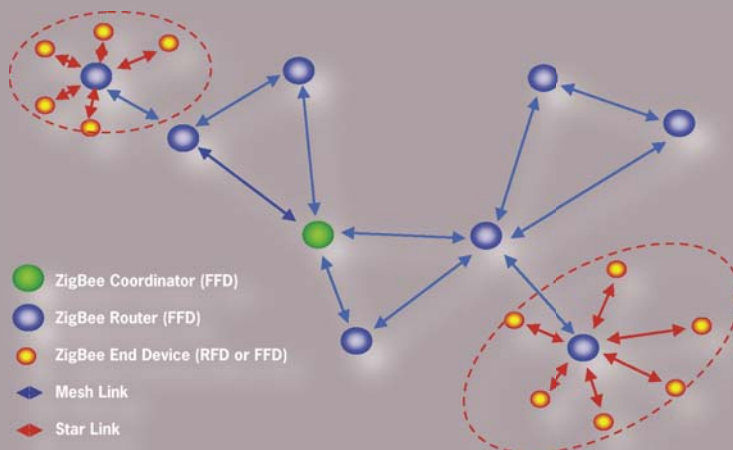

One of the big advantages of ZigBee is the “mesh” capability. Mesh networks allow messages to be passed from node to node such that if any of the nodes fail or drop out, the message can still reach its destination.

Enter the proprietary networks that operate in the ISM (Industrial, Scientific and Medical) bands. Applications such as remote temperature monitoring, pressure and actuation are many times best handled via ISM band. The range or reach of solutions using ISM band is much greater than what can be realized with ZigBee, Bluetooth or WLAN.

FEATURES	IEEE 802.11b	Bluetooth	ZigBee
Power Profile	Hours	Days	Years
Complexity	Very Complex	Complex	Simple
Nodes/Master	32	7	64000
Latency	Enumeration up to 3 seconds	Enumeration up to 10 seconds	Enumeration 30ms
Range	100m	10m	10m-100m
Extendability	Roaming possible	No	Yes
Data Rate	11 Mbps	1 Mbps	250 Kbps
Security	Authentication Service Set ID (SSID)	64 bit, 128 bit	128 bit AES and Application Layer user defined

Power consumption of ZigBee and ISM band is more in line with the expectations for remote monitoring of temperatures, pressures and actuation type data. A ZigBee node can be expected to survive about a year using a AA batteries. The reason for extended battery life on ISM band solutions is the ability of the designer to choose a duty cycle of the data and thus customize the solution to the situation. The worldwide accepted frequency for ZigBee/802.15.4 devices is 2.4GHz using DSSS (Direct Sequence Spread Spectrum) as modulation scheme. This frequency has shorter antennas and a lower overall system cost, for this reason it is a good choice for low cost and longer range industrial and home wireless network.



A ZigBee sensor network may be used for physical parameters, monitoring in industrial applications (temperature, humidity, pressure, gas detector). A mesh sensor network can be created on field and the information may be used for distribution I/O control (without a central PLC or Computer) and/or for remote monitorization.

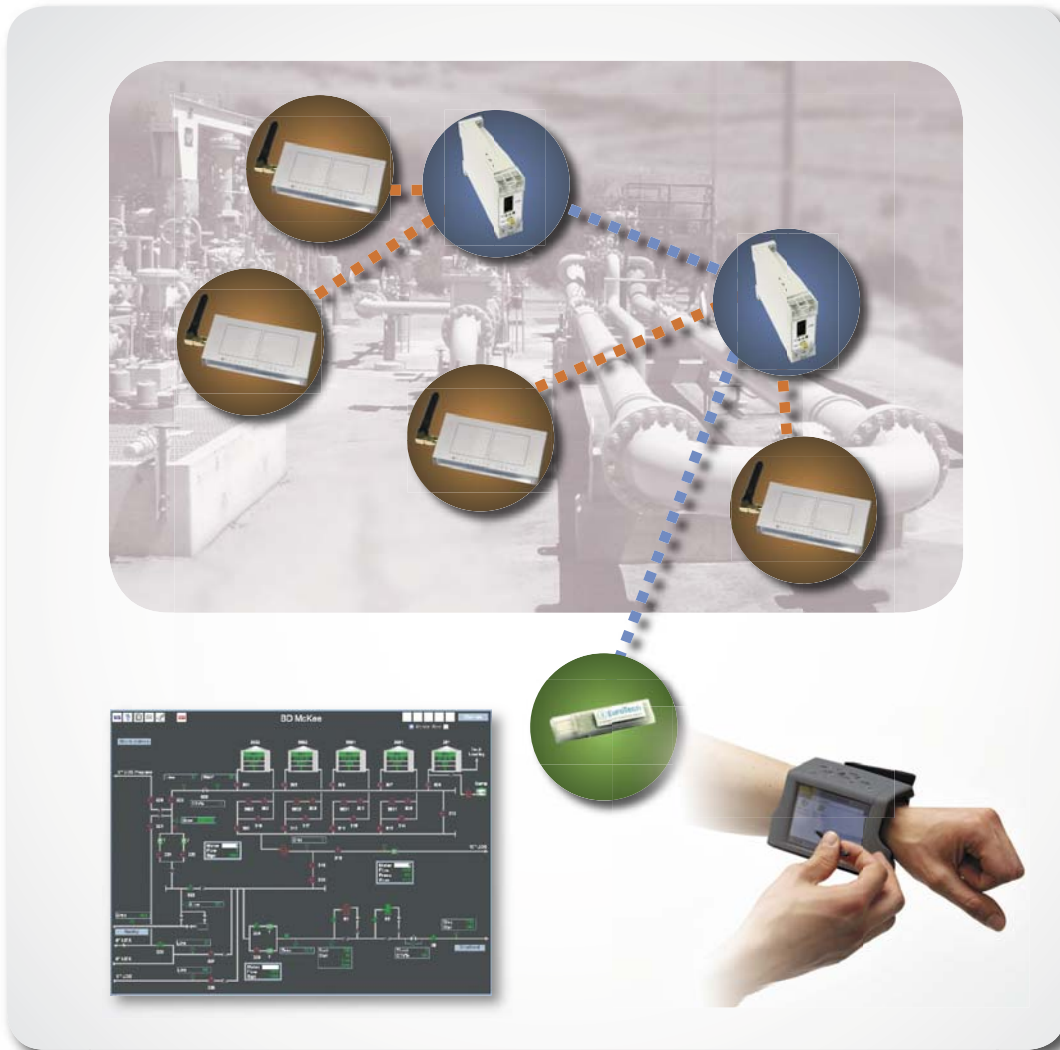

Temperature and humidity monitoring for Hospital/Biological Laboratory

The ZED with PT100 probe placed in the refrigerator and ZRouter is a non intrusive solution for temperature/humidity monitoring. ZED datalogger and Zypad/PC software modules provide historical data, graphical and alarming capabilities. Once implemented, the ZigBee system can assure hospital staff that products are safely stored in monitored refrigerators.





nZB IEEE 802.15.4/ZigBee Module

PN	nZB-01 with internal antenna
PN	nZB-02 with external antenna
Application	Industrial and home automation, Sensor network, Localization, Active RFID
Very Low Power	Operating voltage 2-3.4V – Average current less than 17uA
Frequency Range	2400-2485 MHz – 16 channels
Max Output Power	+3dBm
Electrical Interface	2 UART, 1 IIC Bus (SCL, SDA), 5 GPIO, 6 channel ADC
Protocol	IEEE 802.15.4 / ZigBee Stack
Certification	FCC/CE Mark
Dimensions	Maximum 24x11.8mm h 2.3mm
Operating Temp	-45/+85°C

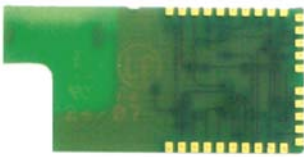

Very Low Power
Frequency Range
Max Output Power
Electrical Interface
Protocol
Certification
Dimensions
Operating Temp

Overview

This module is the right response at any low-data-rate, monitoring, control or automation application that requires long battery life and wireless connectivity. This module provides solutions for wireless sensing and control applications that require networks that support simple point-to-point solutions, to complete ZigBee compliant mesh networks. It is a stand-alone module with an MCU that is in-field programmable and with many pins configurable for a flexible and adaptable use to every field.

Target Applications

- Industrial automation
- Remote monitoring and control
- Domotic
- Remote sensors monitoring
- Medical equipment
- Active RFID
- Localization

Mechanical dimensions [mm]

Mechanical drawing of nZB-01

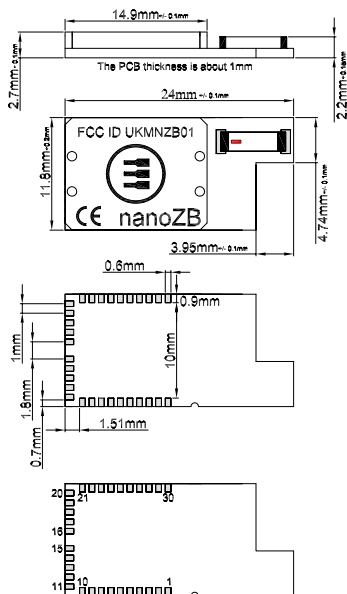

Mechanical drawing of nZB-02

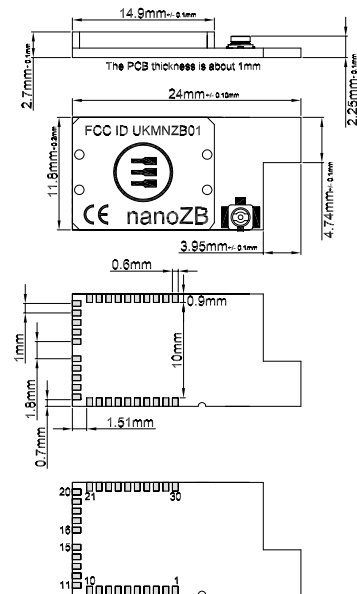

nZB Development Kit

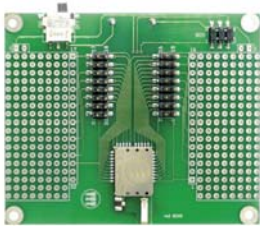

PN	nZB-DevTool
Application	Development tool for Industrial and home automation, Sensor network, Localization, Active RFID
Power	EVB with USB or 2 AAA battery, Bread board with 2 AAA battery
Frequency Range	2400-2485 MHz – 16 channels
Max Output Power	+3dBm
Electrical Interface	2 UART, 1 IIC Bus (SCL, SDA), 5 GPIO, 6 channel ADC
Protocol	IEEE 802.15.4 / ZigBee Stack
Certification	FCC/CE Mark
Boards	N.1 Evaluation board with BDM interface, N.1 Bread board, N.5 nZB modules, N.1 StickBee
Operating Temp	-45/+85°C

Overview

NZB Evaluation Board is a simple portable board which can either be used to test potentialities of NZB module or developing/debugging software for it. NZB Evaluation Board includes a practical on board USB BDM Programmer / Debugger which allows to Program / Debug the on board NZB module or other external HCS08 devices through the BDM connector.

In portable applications of NZB module the board can be battery powered by two common 1.5V AAA batteries. Different ways to supply the board, the programmer/debugger or the on board NZB module are given by either the two mini USB connectors of programmer/debugger module or USB serial converter or the external supply connector.

The BDM Programmer / Debugger based on a Freescale MCU provides a low speed USB 2.0 compatible interface and the inherent USB connector provides plug and play functionality. The firmware programmed on this MCU provides a transparent connection between a computer running CodeWarrior Development Studio for HCS08 version 5.0 to a Freescale HCS08 microcontroller via the microcontrollers BKGD pin. Debugger and software tools can communicate with the tag including downloading of user code into the microcontroller's on-chip flash.

Programming and debugger functions are made possible by the HCS08 microcontroller's Background Debug Controller (BDC) and In-Circuit Emulator (ICE) Debug (DBG) modules. The BKGD line provides a single-wire background debug interface to the on-chip BDC and ICE Debug modules. Even if this interface is provided to the on board target, the BDM port can also be used to interface the programmer/debugger with an external target. For the Normal Mode configuration settings of the Development Board Jumpers, to Program and Debug either the on board NZB module or other HCS08 external targets (including external NZB modules) through the BDM connector CN6, please refer to the NZB Evaluation Board User Manual.



uTOS

IEEE 802.15.2/TinyOS module



PN	uTOS-01 with internal antenna
PN	uTOS-02 with external antenna
Application	Industrial and home automation, Sensor network, Localization, Active RFID
Very Low Power	Operating voltage 2-3.4V – Average current less then 10uA
Frequency Range	2400-2485 MHz – 16 channels
Max Output Power	+3dBm
Electrical Interface	1 UART, 2 DIN, 2 DOUT, 2 channel ADC 12bit
Protocol	IEEE 802.15.4 / TinyOS
Certification	CE Mark
Dimensions	Maximum 51x32mm h 14mm
Operating Temp	-45/+85°C

Overview

WL-2.4 is a wireless, low power, low voltage, battery operated sensor. Power is supplied by one CR2450 coin cell. In a star topology network, battery may last for years with transmission rates of about one packet per minute.

Typical mean battery drain is about 10 μ A (but instantaneous current may rise up to 20 mA during reception). Though external flash requires at least 2.7 V radio is capable to operate down to 2.1 V. Transmission robustness is assured by 802.15.4 physical and MAC layers. WL-2.4 may be used in home automation applications and everywhere a wired link is not feasible. It may operate as stand-alone device or be interfaced to a PC by means of a USB adapter. It may also be interfaced to other boards through an asynchronous serial interface in order to provide low range wireless connectivity. More complex, multihop network topologies are possible with a battery of greater capacity. The module may be used with TinyOS (open source) www.tinyos.net.

ZStick USB/ZigBee stick



PN	ZStick
Application	Coordinator for ZigBee or IEEE 802.15.4 Network
Power	from USB
Frequency Range	2400-2485 MHz – 16 channels
Max Output Power	+3dBm
Protocol	IEEE 802.15.4 / ZigBee Stack
Certification	FCC/CE Mark
PC Interface	ZTC protocol
Operating Temp	-45/+85°C

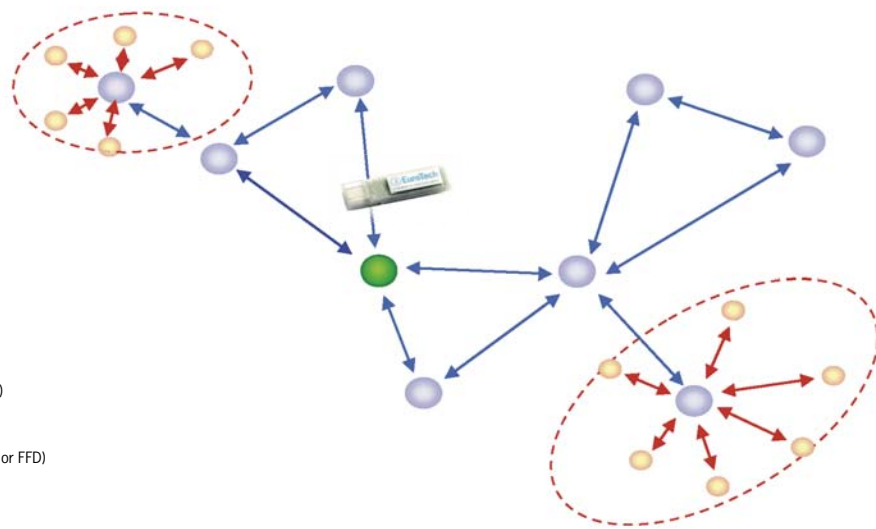

- ZigBee Coordinator (FFD)
- ZigBee Router (FFD)
- ZigBee End Device (RFD or FFD)
- ↔ Mesh Link
- ↔ Star Link



ZRouter

Router for ZigBee mesh network



PN	ZRouter-01 with internal antenna
PN	ZRouter-02 with external antenna
Application	Router for ZigBee or IEEE 802.15.4 Network
Power	9-36V DC
Frequency Range	2400-2485 MHz – 16 channels
Max Output Power	+3dBm
Protocol	IEEE 802.15.4 / ZigBee Stack
Certification	FCC/CE Mark
PC Interface	ZTC protocol
Operating Temp	-45/+85°C

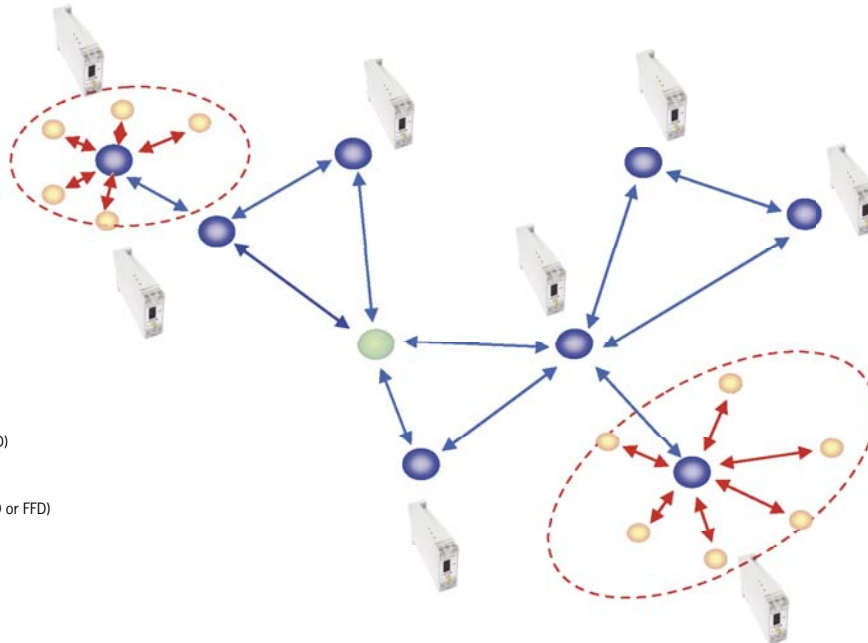

- ZigBee Coordinator (FFD)
- ZigBee Router (FFD)
- ZigBee End Device (RFD or FFD)
- ↔ Mesh Link
- ↔ Star Link

Mechanical dimensions [mm]

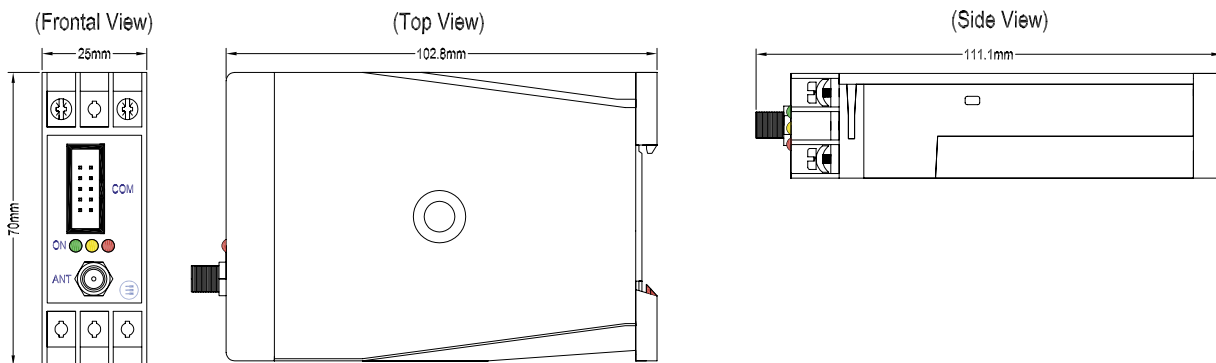

Wireless Sensor Network

ZED: multifunction ZigBee end device family with rechargeable battery



PN	ZED-XX-YYY
XX	01 internal antenna – 02 external antenna
YYY	001 ZigBee data logger with 24bit A/D converter for 100 ZigBee Temperature and humidity sensor - only with internal antenna (XX=01) 120 ZigBee single switch – only with internal antenna (XX=01) 121 ZigBee double switch – only with internal antenna (XX=01)

Application	Industrial and Home Automation: ZigBee End Device
Sensor	PT100, Temperature and Humidity interface, Gas detector, Differential and absolute pressure transducer, etc
Power	Long Life Internal Rechargeable Battery
Frequency Range	2400-2485 MHz – 16 channels
Memory	1 MB internal memory
RTC	On board real time clock
Max Output Power	+3dBm
Antenna	Integrated or External
Wireless Protocol	ZigBee 1.1 – Mesh network
Certification	FCC/CE Mark
Operating Temp	-45/+85°C

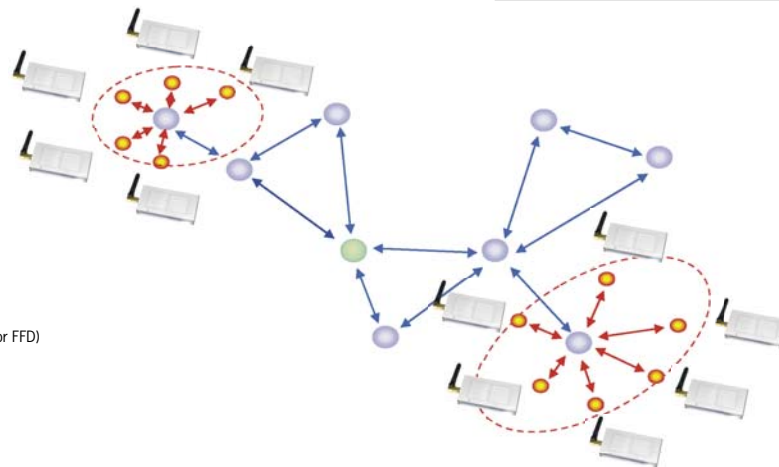

- ZigBee Coordinator (FFD)
- ZigBee Router (FFD)
- ZigBee End Device (RFD or FFD)
- ↔ Mesh Link
- ↔ Star Link

Mechanical dimensions [mm]

Mechanical drawing of ZED-01-1YY

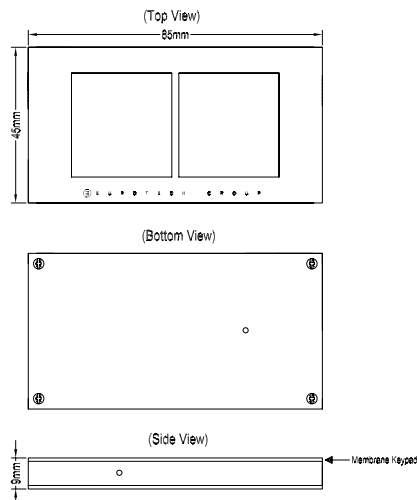

Mechanical drawing of ZED-02-001

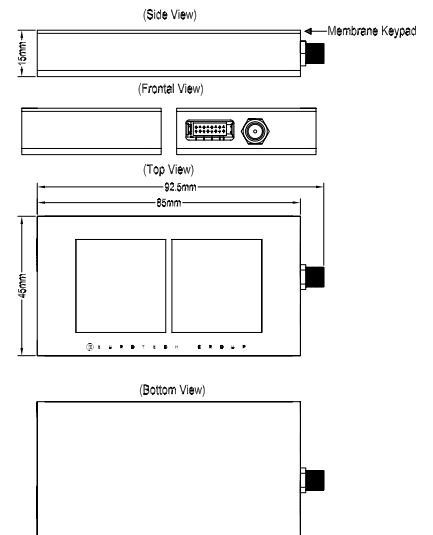



ModBee2400: ModBus-ZigBee mesh network interface



PN	Modbee2400
Application	Industrial and Home Automation: ModBus to ZigBee interface
Power	9-36V DC
Frequency Range	2400-2485 MHz – 16 channels
Max Output Power	+3dBm
Antenna	Integrated or External
Wireless Protocol	ZigBee 1.1 – Mesh network
Certification	FCC/CE Mark/e mark for automotive
Interface	ModBus RTU/ASCII
Operating Temp	-45/+85°C

Overview

ModBee2400 is a Modbus bridge over ZigBee radio protocol stack meant as a Modbus wire replacement. The network comprises one ZC (ZigBee Coordinator) and one or more ZR (ZigBee Router).

The StickBee (a USB Stick) acts as the ZC in the ZigBee network and has to be connected to the Modbus master. The StickBee is itself a Modbus slave allowing either Modbus and ZigBee configuration.

A remote trunk consists of a ZR and one or more Modbus slaves attached to a RS485 bus.

Modbus slave addresses must be unique through the whole network. It is not possible to have more than one Modbus slave with the same address on different remote trunks.

Either the ZC and ZRs are aware of master/slave (or client/server) nature of Modbus protocol.

When a Modbus serial PDU (Protocol Data Unit) is received by the Modbus half of the StickBee, it is encapsulated in a ZigBee ASDU (Application Service Data Unit) and sent through the network to the ZR on which branch is attached the addressed Modbus slave. To do so the Modbus half of the StickBee analyzes the address field of the serial PDU and tries to resolve this in a ZR network address. Then the ZigBee half of the StickBee waits to receive a reply from the addressed ZR. Upon receipt of this reply the ZigBee half of the StickBee removes the serial PDU from the ZigBee ASDU and transmits it on the serial line.

While waiting for the reply the StickBee stops listening to the serial line thus discarding any serial PDU that the master might have transmitted.

While aiming to be as transparent as possible the ZigBee network may introduce latencies that must be understood before setting the response timeout and poll period of the Modbus master.

Sequence charts are provided in this document to help in determining safe values for these parameters.

Mechanical dimensions [mm]

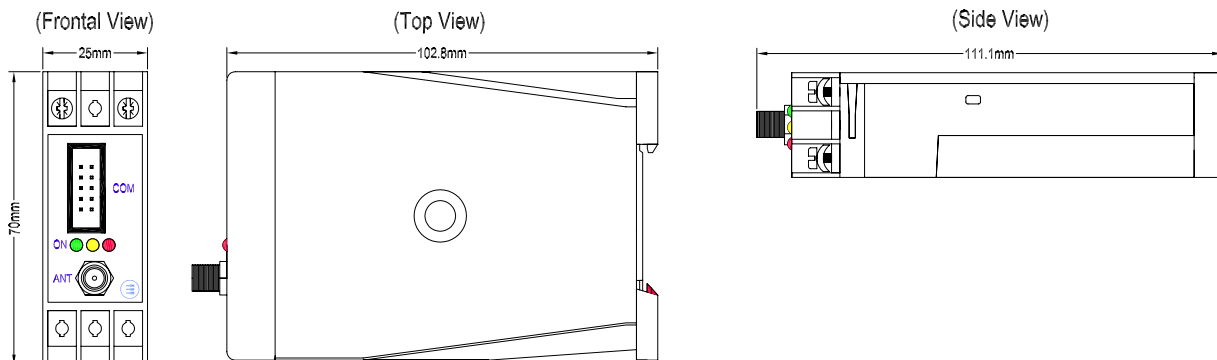

Wearable Computers

Zypad WL1100



Application	Professional Data Acquisition and Management
Display	3.5" TFT 320x240 with touch screen
Memory	128 MB RAM/128 MB FLASH – Mini STUDIO Memory Expansion
Battery Life	Up to 8hrs (*)
Positioning	12 channel GPS receiver
Wireless Connectivity	Wi-Fi 802.11 b/g; Bluetooth class 2 (optional ZigBee version)
Standards	FCC/CE EMC EN55022-024-CSA
Weight	290 gr. with battery and wrist band
Operating Temp	-10/+50°C

(*) depends on features activated

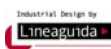

EUROTECH GROUP WORLDWIDE PRESENCE

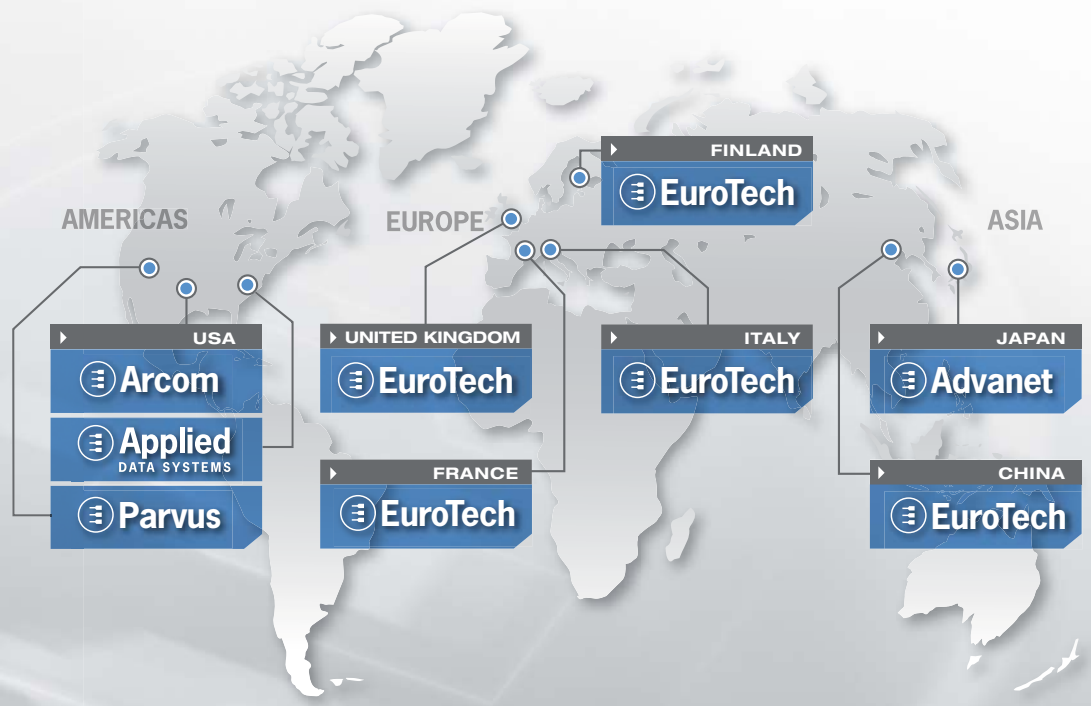

EUROTECH GROUP HEADQUARTERS

EUROTECH S.p.A.
Via Fratelli Solari, 3/a
33020 AMARO (UD) - ITALY
tel. +39.0433 485 411
fax +39.0433 485 499
e-mail: welcome@eurotech.com
www.eurotech.com

AMERICAS

North America

APPLIED DATA SYSTEMS
10260 Old Columbia Road
Columbia, Maryland 21046 - USA
tel. +1 301.490.4007
fax +1 301.490.4582
e-mail: sales@applieddata.net
www.applieddata.net

ARCOM USA
7500 West 161st Street
Overland Park, Kansas 66085 - USA
tel. +1 913.549.1000
fax +1 913.549.1001
e-mail: us-sales@arcom.com
www.arcom.com

PARVUS CORPORATION
3222 So. Washington St.
Salt Lake City, Utah 84115 - USA
tel. +1.800.483.3152
fax +1.801.483.1523
e-mail: sales@parvus.com
www.parvus.com

EUROPE

Central & Southern Europe

EUROTECH Italy
Via Fratelli Solari, 3/a
33020 AMARO (UD) - ITALY
tel. +39.0433 485 411
fax +39.0433 485 499
e-mail: welcome@eurotech.it
www.eurotech.it

Western Europe

EUROTECH France
Parc Club du Moulin à Vent
33, av. Docteur Georges Levy
Batiment 33
69693 VENISSIEUX CEDEX
FRANCE
tel. +33.04.72.89.00.90
fax +33.04.78.70.08.24
e-mail: sales@eurotechfrance.fr
www.eurotechfrance.fr

Northern & Eastern Europe

EUROTECH Ltd
3 Clifton Court, Cambridge,
CB1 7BN - UK
tel. +44 (0) 1223 403410
fax +44 (0) 1223 410457
e-mail: sales@eurotech-ltd.co.uk
www.eurotech-ltd.co.uk

EUROTECH Finland Oy
Kantelettarenkuja 1, PL 73
00420 Helsinki - FINLAND
tel. +358 9 477 888 0
fax +358 9 477 888 99
e-mail: sales@eurotech.fi
www.eurotech.fi

ASIA

ADVANET Japan
616-4, Tanaka,
Okayama 700-0951 - JAPAN
tel. +81-86-245-2861
fax +81-86-245-2860
e-mail: Sales@advanet.co.jp
www.advanet.co.jp

EUROTECH China
ZhongGuanCun East Road Nr. 66
Tri-Tower B, Suite 2207
100080 Beijing - HaiDian District
CHINA
tel. +86.10.62.67.09.04
fax +86.10.62.67.09.54
e-mail: sales@eurotech.com.cn
www.eurotech.com.cn

